



APPROVALS/LISTINGS

Nominal Size Inches /MM		K-Factor Imperial S.I.	Response	Sprinkler Type	APPROVALS		
Thread	Orifice				UL	CUL	CNS
1/2/15	1/2/13	5.6/80	Standard	Upright	Yes	Yes	Yes
1/2/15	1/2/13	5.6/80	Standard	Pendent	Yes	Yes	Yes
1/2/15	1/2/13	5.6/80	Standard	Recessed Up To 1/2" Adjustment	Yes	Yes	Yes
1/2/15	1/2/13	5.6/80	Quick	Upright	Yes	Yes	Yes
1/2/15	1/2/13	5.6/80	Quick	Pendent	Yes	Yes	Yes
1/2/15	1/2/13	5.6/80	Quick	Recessed Up To 1/2" Adjustment	Yes	Yes	Yes

UPRIGHT
PENDENT
RECESSED
SPRINKLERS

RATINGS

SPRINKLER TEMPERATURE CLASSIFICATION	NORMINAL SPRINKLER TEMPERATURE RATING	N.F.P.A MAXIMUM AMBIENT (CEILING) TEMP. (ALLOWED)	GLASS BULB COLOR
Ordinary	135°F / 57°C	100°F / 38°C	Orange
	155°F / 68°C	100°F / 38°C	Red
Intermediate	175°F / 79°C	150°F / 65°C	Yellow
	200°F / 93°C	150°F / 65°C	Green
High	286°F / 141°C	225°F / 107°C	Blue
Extra High	360°F / 182°C	300°F / 149°C	Mauve
Open	Open	--	No Bulb

DIMENSIONS

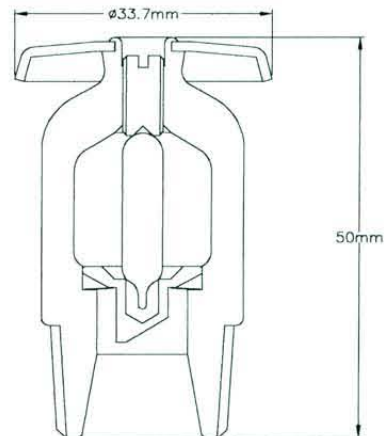
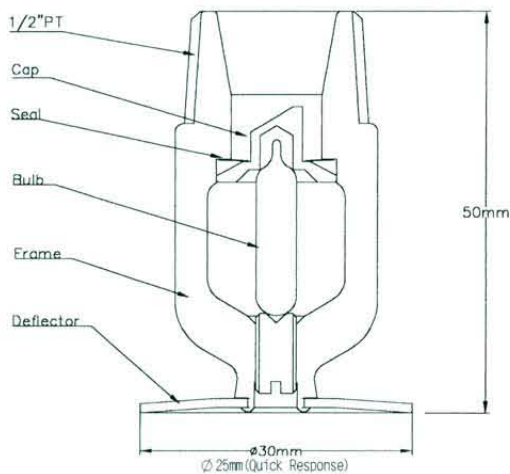

DIMENSIONS

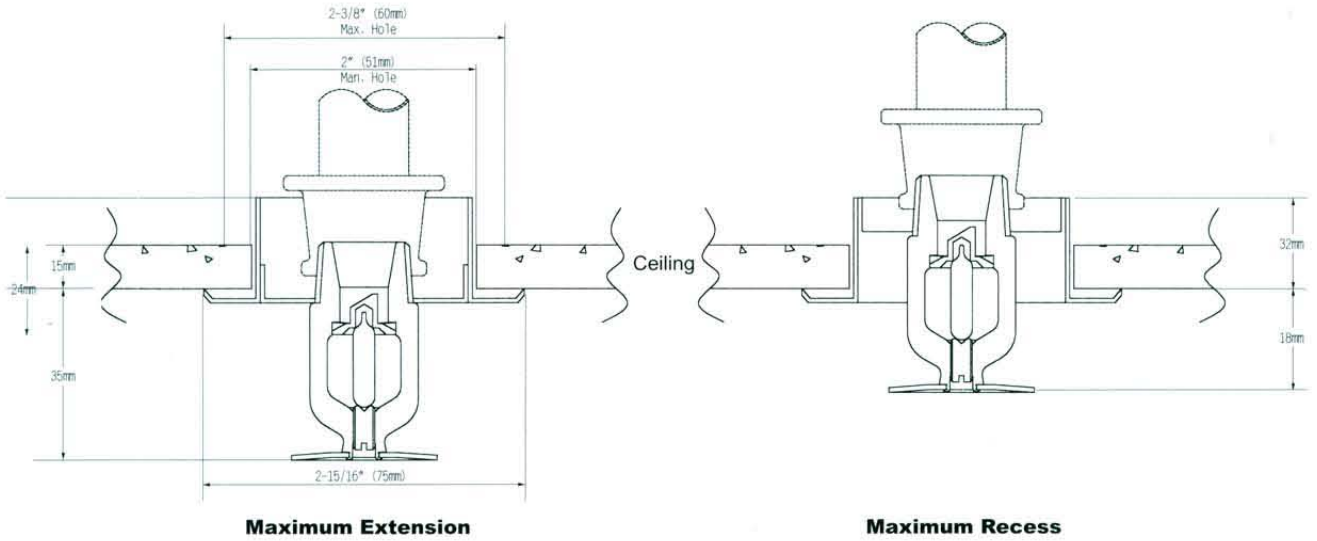

DISCHARGE CURVE

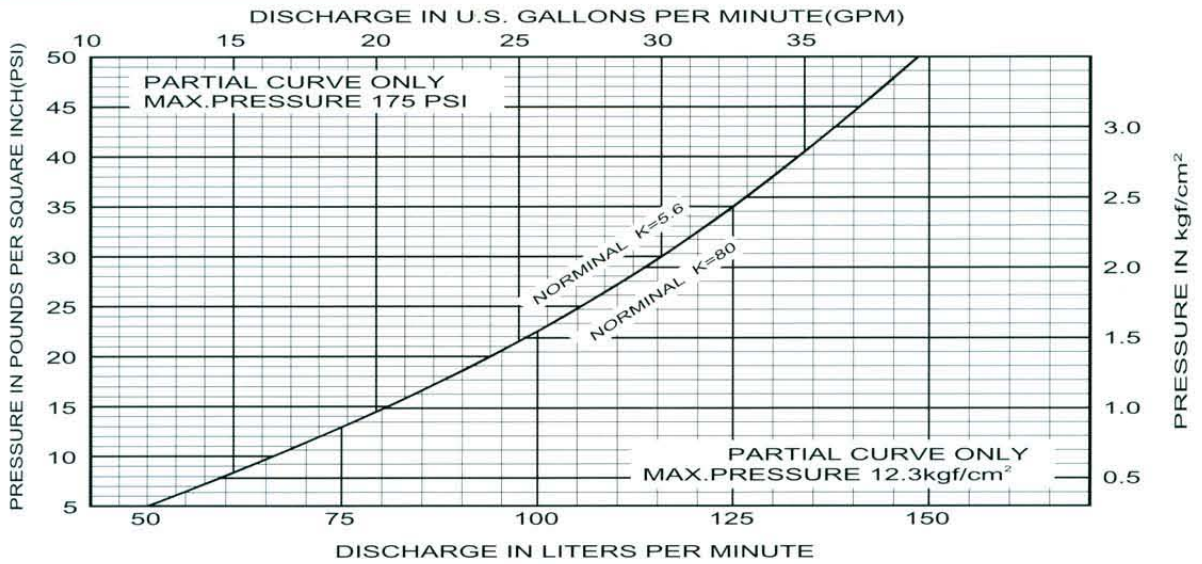

PROTECTOR SPRINKLER